

NOTE:
WHEN STUD AND SHEETROCK CONSTRUCTION IS USED ON THE GUIDE RAIL SUPPORT WALL DOUBLE STUDDING IS NEEDED BEHIND THE 2\"x12\" PLANK FOR SUPPORT. DO NOT USE METAL STUDS.

DETAIL "A"

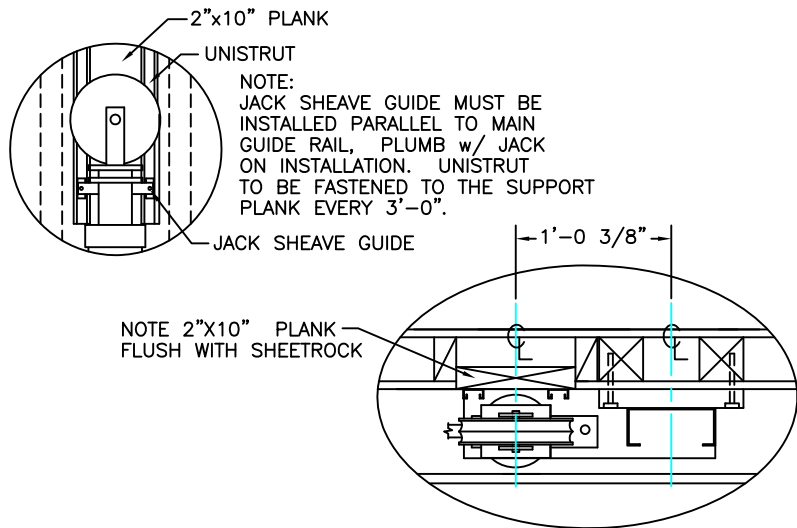

DETAIL "B"

GENERAL CONTRACTOR TO INSTALL STANDARD JAMB BOX IN WALL FOR ELEVATOR HALL STATIONS.

NOTE MAXIMUM DIMENSION.

NOTE
DOOR FRAME CAN BE METAL OR WOOD. SOME STATES REQUIRE FIRE RATED DOORS.

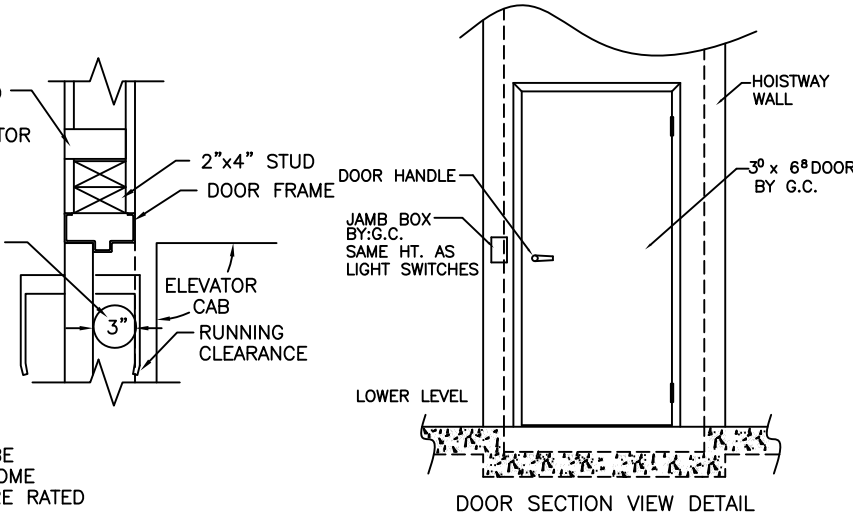

DOOR DETAILS



SHOP DRAWING NAME

ARCHITECT

GENERAL CONTRACTOR

EQUIPMENT INSTALLED BY:
ELEVATOR READY INC.
5060 RITTER ROAD
MECHANICSBURG, PA. 17055
PHONE 717-697-3780
TOLL FREE 888-849-4377

PRIVATE RESIDENCE
HYDRAULIC ELEVATOR

TECHNICAL DATA:

- REACTIONS ON ALL SHEAVES AND MOUNTINGS
STATIC = 1,350 LBS.
IMPACT = 2,700 LBS.
- RAIL FASTENING TO 2\"x12\" PLANK
#14 x 1 3/4\" TYPE A S.M.S. RAIL IS PRE-DRILLED AT FACTORY.
- BOLT FASTENING OF CAR TO TROLLEY
1/2\" - 13 x 4\" SOCKET HD CAP SCREWS

NOTE:
MACHINE ROOM IS LOCATED AT THE UPPERMOST FLOOR LEVEL.

MACHINE ROOM ACCESS DOOR, LATCH AND LOCK FIELD LOCATE.

110v. 1PH DISCONNECT SWITCH BY:G.C.

220v. 1PH 3 POLE DISCONNECT SWITCH FLAT 2\"x10\" PLANK

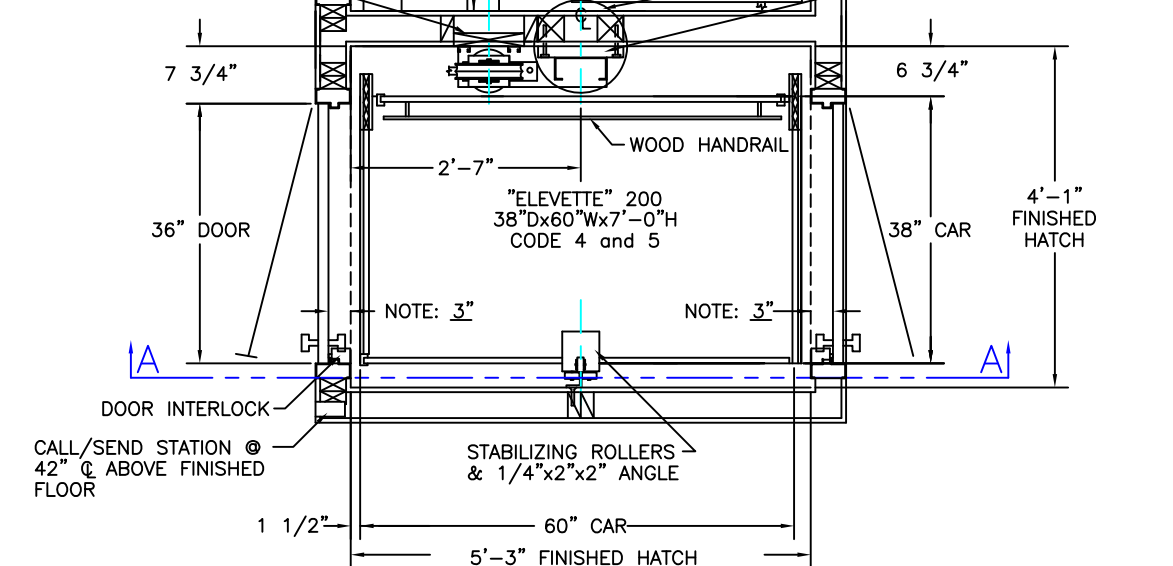

SHAFT PLAN

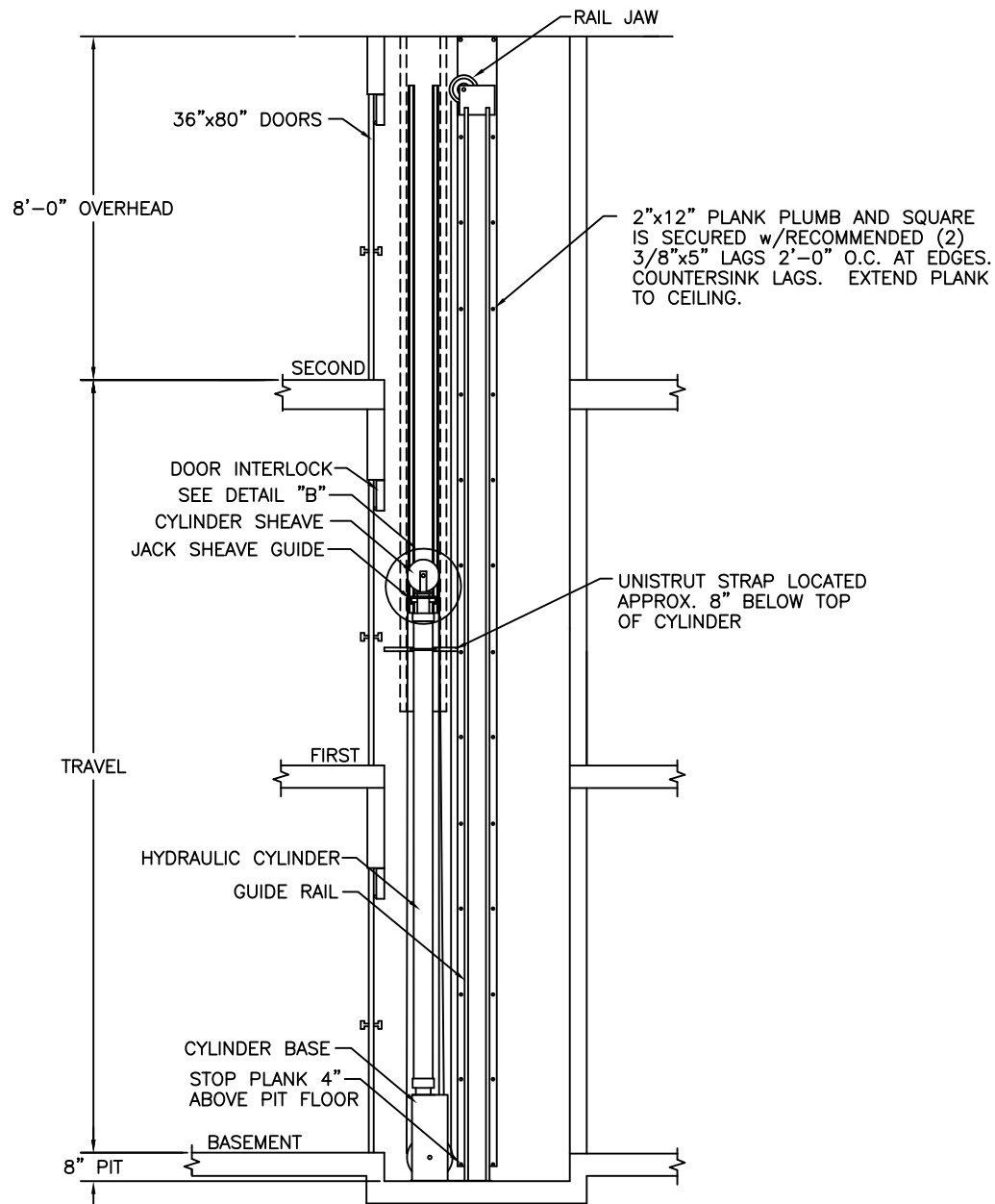

SECTION A-A

SPECIFICATIONS

3 LANDING
HYDRA RIDE II
"ELEVETTE" 200
CAR 38\"Dx60\"Wx7'-0\"H CODE(S) 4 & 5
CAPACITY 750 LBS. AT 30 F.P.M. ±4
2 CABLES 13,200 LBS. T.S. IMP PLOW
STEEL 3/8\" x 8 x 19 IWRC
CAR CONSTRUCTION: 3/4\" HARDWOOD VENEER
COLOR/PANEL SELECTION: PLEASE ADVISE

- ALL DOORS INTERLOCKED
- TELEPHONE CORD
- DOWN LIGHT
- FLOATING GATE
- EMERGENCY LIGHT & ALARM
- IN USE LIGHTS
- ARRIVAL LIGHTS
- HANDRAIL(S) 1" □ BRASS WOOD
- GATE SAFETY BAR
- STABILIZER
- KEYSWITCH OPERATION IN C.O.P.
- ALARM BELL
- LIGHTED BUTTONS
- BATTERY LOWERING
- TELEPHONE CABINET
- HALF TROLLEY
- WHISKER SWITCH
- PIT SWITCH
- WHEELCHAIR HT. CAR CONTROLS

NOTICE TO ELECTRICAL CONTRACTOR:
BRING 4 #10 WIRES TO DISCONNECT SWITCH; (2)-110, (1)-NEUTRAL, (1)-GROUND.
2 1/2 H.P. MOTOR 220 VOLTS 1 ph 60 CYCLE
F.L.A. 10
FUSE 15 AMP SLO BLO
30 AMP MAIN LINE FUSE

NOTE TO ELEVATOR CONTRACTOR OR HIS REPRESENTATIVE: ALL ELECTRICAL WIRING MUST BE DONE BY A JOURNEYMAN MECHANIC AND MUST MEET ALL NATIONAL, STATE, AND LOCAL CODES.

NOTE: ALL HOISTWAY AND MACHINE ROOM CONSTRUCTION MUST COMPLY WITH NATIONAL, STATE, AND LOCAL CODES. PLEASE ADVISE INCOA OF ANY CHANGES NEEDED TO THE DRAWING FOR COMPLIANCE IN YOUR AREA.

SWING TYPE SHAFT DOORS BY OTHERS

DRAWING BY: Chance
DATE:

DRAWING IDENTIFICATION NUMBER

H2 3LA CODE4_5

NOT FOR COMMERCIAL APPLICATION